

**Pioneer Prime Vacuum Assisted
Stage V Diesel-Driven Centrifugal Pump
Sound Attenuated Canopy Package**

100SL-EVO



PUMP SPECIFICATIONS

Model	PP44S8
Size	4 x 4" (100 x 100 mm)
Max Flow	330 m ³ /h
Max Head	23 m
Solids Size	3" (76 mm)

ENGINE SPECIFICATIONS

Engine Type	Perkins 403J-17, Diesel
Displacement	1.7 l
Fuel Consumption at BEP	3.2 l/h @ 1800 rpm
Max Running Hours at BEP	39 h @ 1800 rpm
Continuous Power	25.3 HP (18.9 kW) @ 1800 rpm
Aftertreatment Specifics (DEF, DOC, SCR, etc.)	None Required
Emmissions Compliance	EU Stage V

PRIMING SYSTEM

Priming System	Mechanically Driven Vacuum Pump
Air Removal Capacity	24 l/s (50CFM)
Priming Chamber	Air Separation Pioneer Prime w/SS Components
Discharge Check Valve	Ductile Iron Body; Swing Flex Nitrile Rubber Flapper
Run Dry System	Oil Reservoir for Mechanical Seal; Indefinite Run-Dry Capability

FEATURES

- Indefinite Run-Dry Capability
- Environmentally Safe Priming System with Patented PosiValve™
- Spark Arresting Silencer
- Auxiliary Fuel Tank Connections
- Digital Fuel Level Gauge
- Suction & Discharge Pressure Gauges
- Quick Connect Suction & Discharge Couplings

OPTIONS AND ACCESSORIES

Telemetry	Full Control & Remote Monitoring with Alerts
Certified Spark Arrestor Trailers	ATEX Approved EU Approved, Fast Tow or Plant Trailers & Heavy Duty Non-EU Site Tow Trailer
Safety	Air Intake Shutdown Valve
Battery Standby	Solar Panel Trickle Charger
Materials	Duplex Stainless Steel Available

PACKAGE SPECIFICATIONS

Fuel Tank Capacity	125 l
Control Panel	E100 Auto Stop/Start
Operating Speed (Min. / Max.)	1400 - 1800 rpm
Weight (Dry / Wet)	1050 kg / 1150 kg
Dimensions (L x W x H)	2033 x 940 x 1300 mm
Enclosure dB(A) Rating	65 dB(A) @ 7m
Canopy Material & Finish	Zinc Plated Steel, Painted Green RAL6005
Skid/Bund Material & Finish	Carbon Steel, Hot Dip Galvanised

MATERIALS OF CONSTRUCTION

Impeller	CA6NM Stainless Steel
Shaft	17-4 PH Stainless Steel
Wear Ring	ASTM A48 Class 40 Gray Iron
Volute	Ductile Iron ASTM A536 65-45-12
Mechanical Seal	Silicon Carbide Rotating vs Tungsten Carbide Stationary, Fluoroelastomers

MECHANICAL DIMENSIONS & WEIGHTS

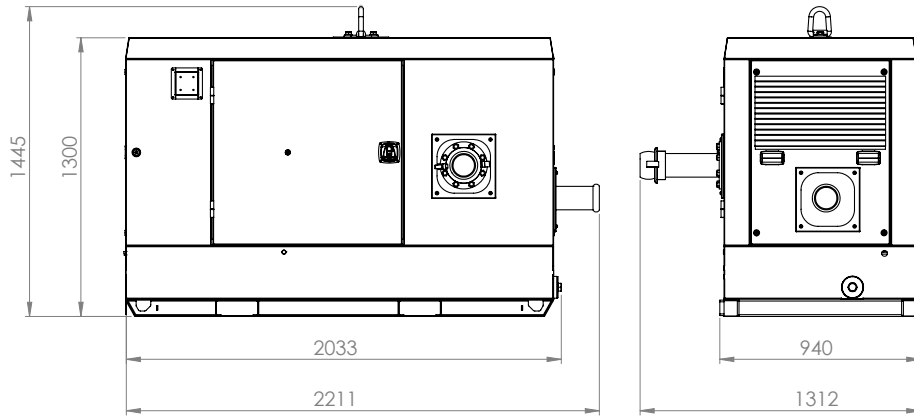

Weight (Dry / Wet): 1050 kg / 1150 kg

PERFORMANCE CURVE

Model: PP44S8

Impeller Diameter: 8.25"

Solids Size: 3"

